

The Reflective Open Box (ROB) Solar Cooker

Materials:

- 2- large moving boxes (Lowes has 24" x 18" x 18" - \$1.78 each)
- aluminum foil
- heavy duty scissors (or utility knife with parent assistance!!!)
- white glue
- packing tape or some other wide strong tape
- plastic oven bag
- small black cooking vessel or pot (a pint Mason jar painted black or covered with black paper might work)

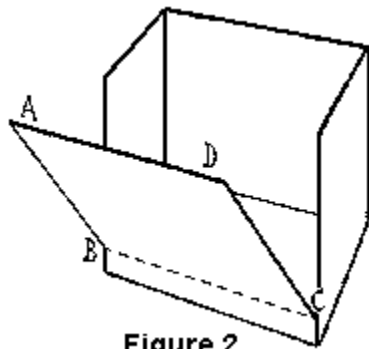

Figure 2

Construction

To make an ROB, assemble one cardboard box by taping the bottom closed, cut off the top flaps, and lay on the longest side. Cut off the top flaps. On one of the broader sides, draw a horizontal line (BC) about two inches above the bottom (figure 2) and cut the seams along AB (stop at B) and DC (stop at C). Fold down the front panel ABCD using BC as a hinge. Stack a few rectangular pieces of cardboard in the bottom of the box, to raise the floor level up to the level of BC.

Cut the long sides of the second box and tape together so that it can be inserted into the box to form panels 1 and 2 in figure 3. The angle formed by these panels is adjustable at time of construction. Smaller angles concentrate the sun more, but require more frequent adjustment to follow the sun. A good compromise seems to be any angle between 60 and 90 degrees. Cover this piece with aluminum foil and glue it in place. Apply aluminum foil to panels 3 and 4 as well. *Keep the aluminum foil as smooth as possible.*

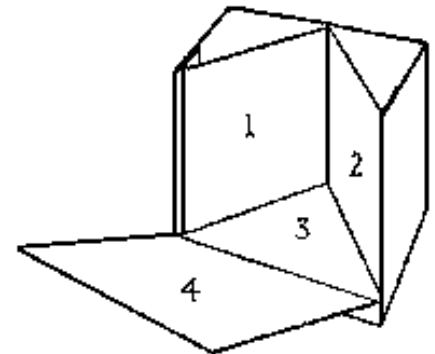

Figure 3

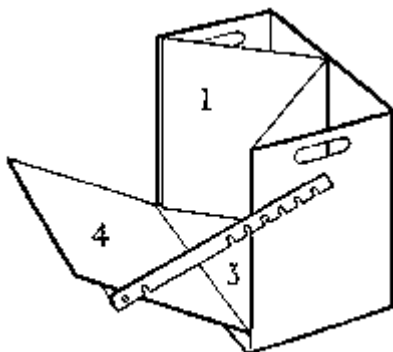

Figure 4

The ROB shown in the photograph at the top of the page has the following over-all dimensions: Length: 46 cm (18"), Width: 32 cm (12.5"), and height: 42 cm (16.5"). These dimensions correspond to a reflective area of about 5,000 sq. cm. (770 sq. in.) which proved sufficient to cook for two persons.

A wooden prop can be used to adjust the front panel (figure 4). The single notch near panel 4 is used to lock this panel in a closed position for storage. Rocks can be placed in the triangular chambers behind panels 1 and 2 to stabilize the cooker in the wind.

When cooking with the oven you will need to put the cooking pot inside a plastic oven bag or place a clear glass bowl over the pot in order to trap the heat (figure 1).



Figure 1

